

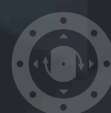

## Eleflex

Electromagnetic Brakes  
**Freni elettromagnetici**





SINCE  
'74

# RE-SOLVING

MACHINING LAMINATES REQUIRES AUTOMATED PROCESSES, AND AUTOMATION REQUIRES A RANGE OF EQUIPMENT DESIGNED TO OPTIMISE PRODUCTION AND REDUCE TIMES, COSTS AND THE RISK OF ERROR. IF YOU WANT TO FIND ALL THIS IN ONE BRAND NAME ONLY, ASK AND ASK AGAIN. THE ANSWER WILL ALWAYS BE: **RE**.

LA LAVORAZIONE DEI LAMINATI RICHIEDE PROCESSI AUTOMATIZZATI. L'AUTOMAZIONE RICHIEDE EQUIPAGGIAMENTI DIVERSI, TUTTI MIRATI A OTTIMIZZARE LA PRODUZIONE, RIDUCENDO TEMPI, COSTI E RISCHI DI ERRORE. SE VUOI TROVARE TUTTO IN UN NOME SOLO, CHIEDI E RICHIEDI. IN MOLTI TI DIRANNO: **RE**.



The ELEFLEX range of electromagnetic powder brakes and clutches is one of our most tried and tested products, and has been in production for over 40 years. This wealth of experience, covering thousands of applications in a various sectors, the research into innovative materials and the continuous studies carried out into how these brakes perform have permitted us to acquire extensive know-how, and continually improve our product.

ELEFLEX range of brakes and clutches features:

- High precision torque control,
- Small size,
- No pollutants produced,
- Reduced residual torque.

For these reasons, they are particularly suitable for use in the printing sector, flexographic and rotogravure machines, but also in food preparation areas or locations with stringent hygiene and dust emission tolerances, such as in clean rooms. They are ideal for use in the food-packaging sector, on laminating or plastic film machines and all applications involving low web tension, thanks to their very low residual torque.

La serie ELEFLEX di freni e frizioni a polvere elettromagnetica è uno dei nostri più collaudati prodotti che produciamo da oltre 40 anni.

L'esperienza maturata con migliaia di applicazioni in svariati settori, la ricerca di materiali innovativi e il continuo studio del comportamento di questi freni ci hanno permesso di accrescere il nostro know-how apportando continue migliorie al nostro prodotto.

La gamma ELEFLEX di freni e frizioni garantisce:

- Alta precisione nel controllo della coppia,
- Compattezza,
- Nessuna emissione di materiale inquinante,
- Coppia residua ridotta.

Particolarmente indicati nel settore della stampa, su macchine flessografiche e rotocalco, trovano ampio uso anche in ambienti alimentari o particolarmente esigenti in quanto a pulizia ed emissione di polveri, come le camere bianche. Ideali nel settore food-packaging, su macchine laminatrici o per il film plastico, ed in tutte quelle applicazioni con tiri molto bassi grazie alle ridottissime coppie residue.



This catalogue information is correct at date of publication, but is subject to change without prior notification, or as required by Re S.p.A. Technical data are also illustrative and for product selection, while designing the application we recommend you to get an opinion from our sales-engineer, in order to select the most suitable size.

I dati del presente catalogo sono ritenuti corretti al momento della pubblicazione, ciò non implica responsabilità da parte della Re S.p.A. per eventuali variazioni intervenute successivamente. È inoltre consigliato, in fase di progettazione dell'applicazione, consultare i nostri tecnici commerciali in modo da selezionare il modello più idoneo.

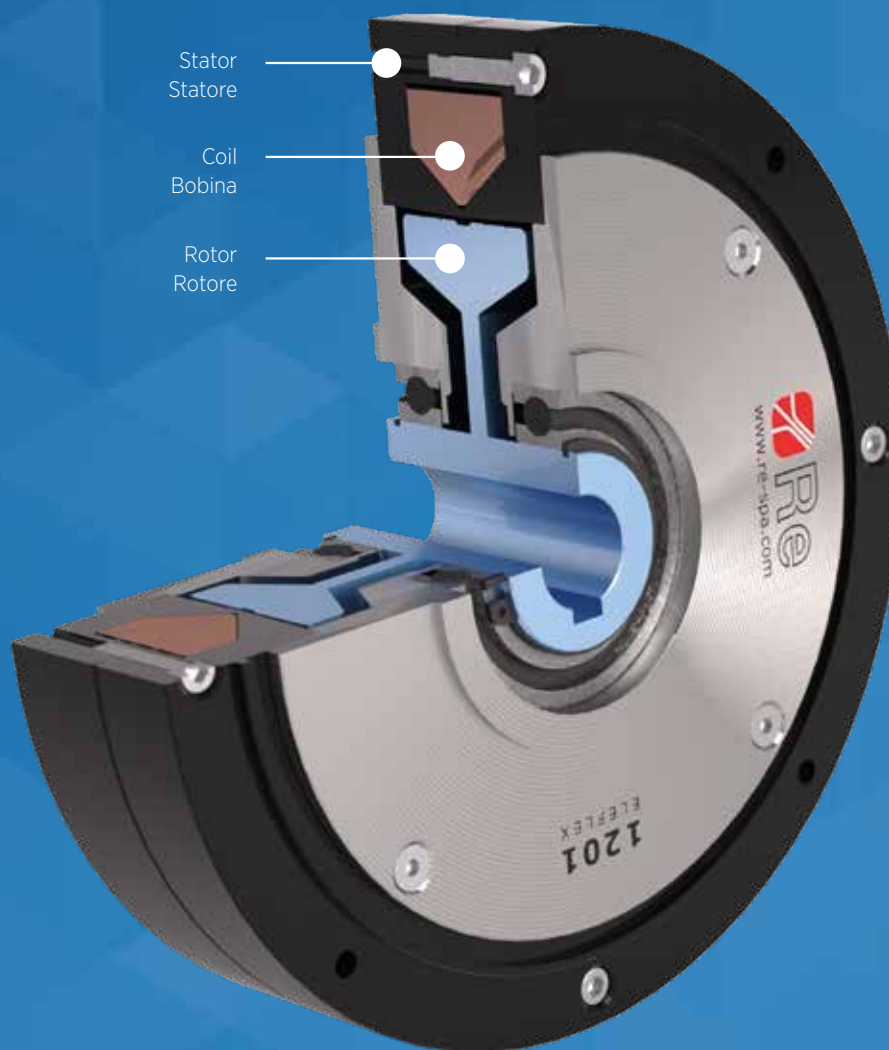

From the constant research of new solutions to improve our products' performances is born a new generation of ELEFLEX brakes: the new engineering of these brakes, has a special design that lowered the iron circuit residual magnetism and the mechanical friction, bringing down the residual torque to less than 1% of the nominal torque.

The torque of these new brakes is independent of rotor speed (within the recommended operating range from 40 to 2000 RPM) and it can vary by 5% keeping constant current supply.

Dalla continua ricerca di nuove soluzioni che possano migliorare le prestazioni dei nostri prodotti è nata una nuova generazione di freni ELEFLEX: la nuova ingegnerizzazione dei freni a polvere Re, presenta uno speciale sistema in grado di abbattere il magnetismo residuo e l'attrito meccanico, portando la coppia residua a meno dell'1% di quella nominale.

La coppia dei nuovi freni è indipendente dalla velocità di scorrimento del rotore (entro la gamma di funzionamento raccomandata dai 40 ai 2000 RPM), e può subire un'oscillazione massima del 5% in presenza di costante intensità di corrente.



## ✓ **New engineering**

nuova ingegnerizzazione

## ✓ **Lowering of the iron circuit residual magnetism**

abbattimento del magnetismo residuo

## ✓ **Lowering of the mechanical friction**

abbattimento dell'attrito meccanico

✓ < 1%

## **Residual torque less than**

coppia residua inferiore

✓ 5%

## **Max torque variation**

max oscillazione della coppia

✓ 40-2000 rpm

## **Recommended operating range**

gamma di funzionamento raccomandata

## ✓ **Torque independent of (rotor) speed**

coppia indipendente dalla velocità

## **Operating principle**

The electromagnetic powder brake consists of three basic components: a coil, a stator and a rotor. When current is supplied to the brake, the magnetic field inside the coil starts to vary in proportion to the size of the current. The variations in the magnetic field alter the viscosity of the special powder positioned between the rotor and the stator.

## **Principio di funzionamento**

Il freno a polvere elettromagnetica è costituito da tre parti fondamentali: una bobina, uno statore ed un rotore. Fornendo corrente al freno, all'interno della bobina si avrà una variazione del campo magnetico proporzionale all'intensità di corrente stessa. La variazione del campo magnetico modifica la viscosità della speciale polvere situata tra il rotore e lo statore.

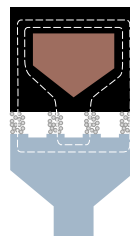

When an electrical current is applied to the coil, the particles are aligned along the magnetic field force lines, creating a dragging bond between the rotor and the stator, thereby generating the braking effect.

Quando la bobina viene eccitata elettricamente le particelle si orientano in base alle linee di forza del campo magnetico determinando un legame di trascinamento tra il rotore e lo statore e permettendo così la frenatura.



When the current is disconnected, the powder is pushed against the stator by the centrifugal force, thus releasing the rotor so that it can rotate.

Quando viene tolta la corrente la polvere viene schiacciata contro lo statore dalla forza centrifuga lasciando così il rotore libero di ruotare.



## THE ELEFLEX RANGE

The powder brakes range from the tiny B.20 that produces 2 Nm of torque, up to the B.5000 that generates 500 Nm, and can be fitted with additional heat dissipation devices, such as ring heat-sinks or fans, in order to prolong the life of the brake.



brake  
freno



brake with fan  
freno con ventilatore



brake with radiator  
freno con radiatore



clutch with radiator  
frizione con radiatore

## LA GAMMA ELEFLEX

La gamma dei freni a polvere parte dai piccolissimi B.20 con 2 Nm di coppia fino ai B.5000 da 500 Nm, con la possibilità di incrementare la dissipazione del calore attraverso l'ausilio di anelli radianti o ventilatore, aumentando così la vita utile del freno.

## SPECIAL APPLICATIONS

Our technical department is available to discuss any special applications, working together to achieve our customers needs. We already designed special solutions for some customers, as for example:











- brakes and clutches working at lower speeds (as low as 10 RPM) or at higher speed (more than 2000 RPM),
- brakes with high performance cooling fans (1),
- special brakes and clutches for vertically mounted applications (2).

## APPLICAZIONI SPECIALI

I nostri uffici tecnici sono sempre a disposizione della clientela per collaborare insieme allo sviluppo di nuove soluzioni, personalizzate in base alle loro esigenze. Sono già state progettate per alcuni clienti soluzioni speciali, tra cui:

- freni e frizioni in grado di lavorare a bassissime velocità (fino a 10 RPM) o altissime velocità (superiori a 2000 RPM),
- freni con ventilazione potenziata (1),
- freni speciali per applicazioni con asse verticale (2).



		<b>Torque Nm</b> Coppia nominale Nm	<b>Residual torque Nm</b> Coppia residua Nm	<b>Current A</b> Corrente A	<b>Resistance Ohm</b> Resistenza Ohm	<b>Voltage V</b> Tensione V	<b>Power dissipation W</b> Potenza dissipabile W
<b>B.20</b>		2	0,07	1	24	24	24
<b>B.53</b>		5	0,03	1	24	24	70
<b>B.55</b>		5	0,04	1	24	24	75
<b>B.121</b> <b>C.121</b>		12	0,06	1	24	24	80
<b>B.351</b> <b>C.351</b>		35	0,2	1	24	24	130
<b>B.651</b> <b>C.651</b>		65	0,4	1	24	24	170
<b>B.1201</b> <b>C.1201</b>		120	0,5	1	24	24	330
<b>B.1701</b> <b>C.1701</b>		170	0,5	1	24	24	450
<b>B.2500</b> <b>C.2500</b>		250	3	0,94	25,5	24	500
<b>B.5000</b> <b>C.5000</b>		500	6	0,94	25,5	24	1300



# SYMBOLS AND UNIT OF MEASUREMENT

## SIMBOLI E UNITÀ DI MISURA

<b>Cd</b> <sup>min</sup> <sub>max</sub>	Minimum/maximum dynamic torque [Nm]	Coppia dinamica minima/massima [Nm]
<b>J</b>	Total inertia load [Kgm <sup>2</sup> ]	Inerzia [Kgm <sup>2</sup> ]
<b>n</b> <sup>min</sup> <sub>max</sub>	Minimum/maximum revolutions per minutes [rpm]	Numero di giri minimo/massimo [rpm]
<b>t</b>	Braking time [s]	Tempo di frenatura [s]
<b>v</b>	Web speed [m/min]	Velocità lineare [m/min]
<b>T</b> <sup>min</sup> <sub>max</sub>	Minimum/maximum web tension [N]	Tensione minima/massima sul materiale [N]
<b>D</b> <sup>min</sup> <sub>max</sub>	Minimum/maximum roll diameter [m]	Diametro minimo/massimo bobina [m]
<b>Pc</b>	Heat dissipation in continuous slipping [W]	Potenza dissipata in calore durante lo slittamento continuo [W]
<b>Pcf</b>	Clutch's heat dissipation in continuous slipping [W]	Potenza dissipata dalla frizione in calore durante lo slittamento continuo [W]
<b>m</b>	Roll maximum weight [kg]	Peso massimo bobina [kg]
<b>r</b>	Roll maximum radius [m]	Raggio massimo bobina [m]
<b>Ts</b>	Web tension per centimeter [N/cm]	Tensione sul materiale per centimetro [N/cm]
<b>Lg</b> <sup>min</sup> <sub>max</sub>	Minimum/maximum web width [cm]	Larghezza materiale minima/massima [cm]

# GUIDE FOR BRAKE/ CLUTCH SELECTION

## GUIDA ALLA SCELTA DEL FRENO/FRIZIONE

Specific tension values for typical converting materials  
Valori di tensione consigliati per singolo materiale

Paper Carta	Weight g/m <sup>2</sup> Peso g/m <sup>2</sup>	10	30	60	100	150	200
	Web tension per centimeter Ts N/cm Tensione per centimetro Ts N/cm		0,3	1	2,5	3,2	4
Cellophane (N/cm for $\mu$ of thickness) Cellophane (N/cm per $\mu$ di spessore)							0,042
Polyethylene (N/cm for $\mu$ of thickness) Polietilene (N/cm per $\mu$ di spessore)							0,02
Polypropylene oriented (N/cm for $\mu$ of thickness) Polipropilene orientato (N/cm per $\mu$ di spessore)							0,025
Aluminium foil (N/cm for $\mu$ of thickness) Alluminio in foglia ricotto (N/cm per $\mu$ di spessore)							0,025



# USEFUL FORMULAS

## FORMULE UTILI

$$J = \frac{m \cdot r^2}{2} = \text{Kgm}^2$$

Roll inertia  
Inerzia bobina

$$n = \frac{v}{\pi \cdot D \text{ max/min}} = \text{rpm}$$

Minimum/maximum revolutions per minute  
Numero di giri minimo/massimo

$$v = \pi \cdot D \cdot n = \text{m/min}$$

Web speed  
Velocità lineare

## TENSIONING

### SLITTAMENTO CONTINUO

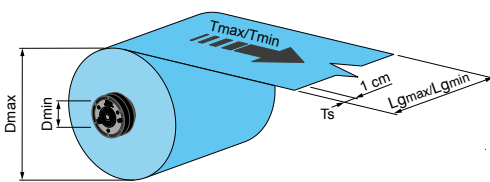

## CALCULATION EXAMPLE

### ESEMPIO DI CALCOLO

Polypropylene oriented foil - thickness 40 μ  
Nastro di polipropilene orientato - spess. 40 μ

Dmax	= 0,8 m	Dmin	= 0,1 m
Lgmax	= 120 cm	Lgmin	= 40 cm
V	= 180 m/min	m	= 700 kg

$$T_{\text{max}} = T_s \cdot L_{\text{gmax}} \quad \text{Maximum web tension} \\ \text{Tensione massima sul materiale}$$

$$T_{\text{max}} = (0,025 \text{ N/cm} \cdot 40 \mu) \cdot 120 \text{ cm} = 120 \text{ N}$$

$$T_{\text{min}} = T_s \cdot L_{\text{gmin}} \quad \text{Minimum web tension} \\ \text{Tensione minima sul materiale}$$

$$T_{\text{min}} = 1 \text{ N/cm} \cdot 40 \text{ cm} = 40 \text{ N}$$

$$C_{\text{dmax}} = \frac{D_{\text{max}} \cdot T_{\text{max}}}{2} \quad \text{Maximum dynamic torque} \\ \text{Coppia dinamica massima}$$

$$C_{\text{dmax}} = \frac{0,8 \text{ m} \cdot 120 \text{ N}}{2} = 48 \text{ Nm}$$

$$C_{\text{dmin}} = \frac{D_{\text{min}} \cdot T_{\text{min}}}{2} \quad \text{Minimum dynamic torque} \\ \text{Coppia dinamica minima}$$

$$C_{\text{dmin}} = \frac{0,1 \text{ m} \cdot 40 \text{ N}}{2} = 2 \text{ Nm}$$

$$n_{\text{min}} = \frac{v}{D_{\text{max}} \cdot \pi} \quad \text{Minimum revolutions per minutes} \\ \text{Numero di giri minimo}$$

$$n_{\text{min}} = \frac{180 \text{ m/min}}{0,8 \text{ m} \cdot \pi} = 72 \text{ rpm}$$

$$n_{\text{max}} = \frac{v}{D_{\text{min}} \cdot \pi} \quad \text{Maximum revolutions per minutes} \\ \text{Numero di giri massimo}$$

$$n_{\text{max}} = \frac{180 \text{ m/min}}{0,1 \text{ m} \cdot \pi} = 573 \text{ rpm}$$

$$P_c = \frac{T_{\text{max}} \cdot v}{60} \quad \text{Heat dissipation in continuous slipping} \\ \text{Pot. dissipata in calore in continuo}$$

$$P_c = \frac{120 \text{ N} \cdot 180 \text{ m/min}}{60} = 360 \text{ W}$$

$$P_{\text{cf}} = \frac{C_{\text{dmax}} \cdot (n_{\text{max}} - n_{\text{min}})}{9,55} \quad \text{Clutch's heat dissipation in} \\ \text{continuous slipping} \\ \text{Pot. dissipata dalla frizione in calore} \\ \text{durante lo slittamento continuo}$$

$$P_{\text{cf}} = \frac{48 \text{ Nm} \cdot (573 - 72 \text{ rpm})}{9,55} = 2518 \text{ W}$$

## STOP BRAKING

### FRENATURA DI ARRESTO

$$C_{\text{dmax}} = \frac{m \cdot D_{\text{max}} \cdot v}{240 \cdot t} = \text{Nm} \quad \text{Dynamic torque} \\ \text{Coppia dinamica}$$

$$C_{\text{dmax}} = \frac{700 \text{ kg} \cdot 0,8 \text{ m} \cdot 180 \text{ m/min}}{240 \cdot 8 \text{ s}} = 52,5 \text{ Nm}$$

## CALCULATION EXAMPLE

### ESEMPIO DI CALCOLO

t = 8 s

RECOMMENDED BRAKE / FRENO CONSIGLIATO B.651.V  
RECOMMENDED CLUTCH / FRIZIONE CONSIGLIATA C.1701.R



## MINI MODELS

These models are mainly used in the textile and metal wire sectors where applications providing low web tension and precise control of the tension applied to the material are essential.

Our technical offices are able to provide customers with applications that satisfy their specific requirements, including brakes fitted with radiators or fans, or design special miniature clutch or brake models.

## MODELLI MINI

Questi modelli sono utilizzati prevalentemente nel settore tessile e nella lavorazione del filo metallico, dove sono necessarie applicazioni con tiri molto bassi e un accurato controllo della tensione del materiale.

I nostri uffici tecnici sono a disposizione del cliente per studiare l'applicazione più corretta in base al tipo di esigenza, integrando eventualmente un radiatore o un ventilatore, o progettando un nuovo modello di freno-frizione mini.

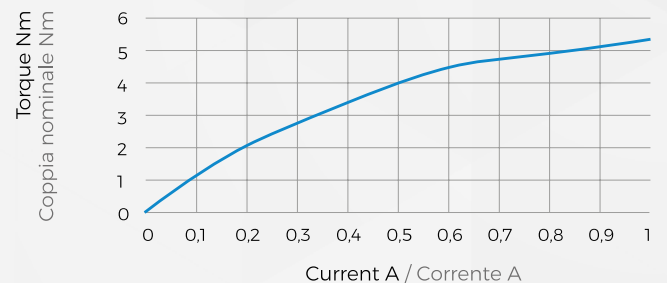
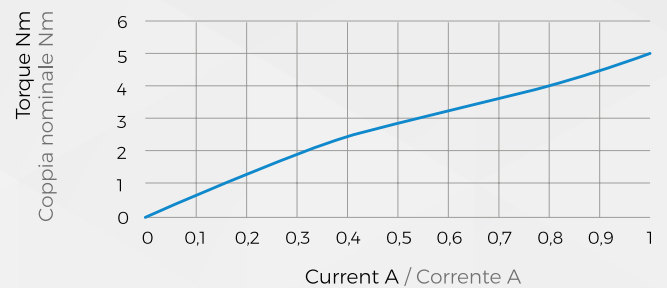
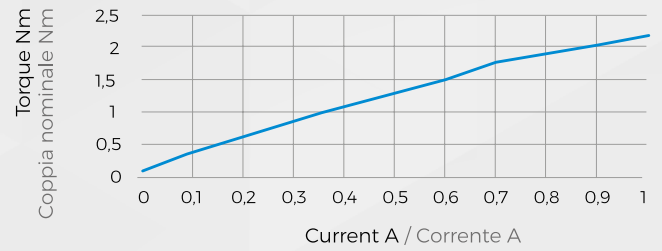

## B.20

No. 3 threaded holes  
M4 for fastening  
N°3 fori per viti M4 per  
fissaggio macchina

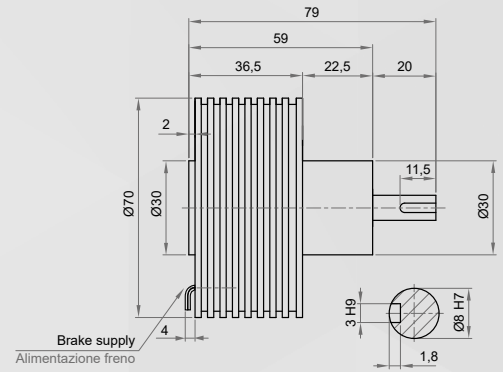
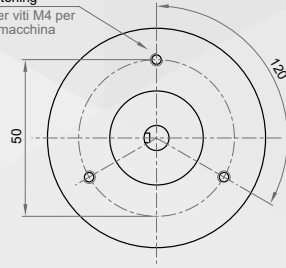

## B.53

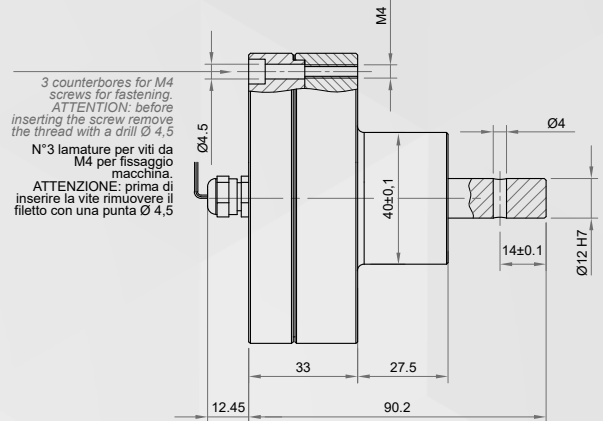
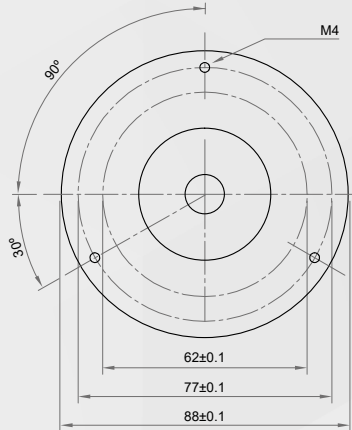

## B.55

No. 3 counterbores for  
M4 screws for fastening  
N°3 fori per viti M4 per  
fissaggio macchina

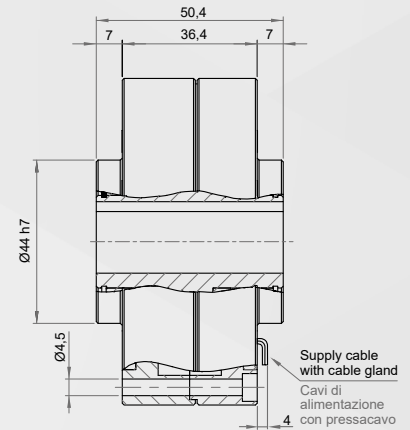
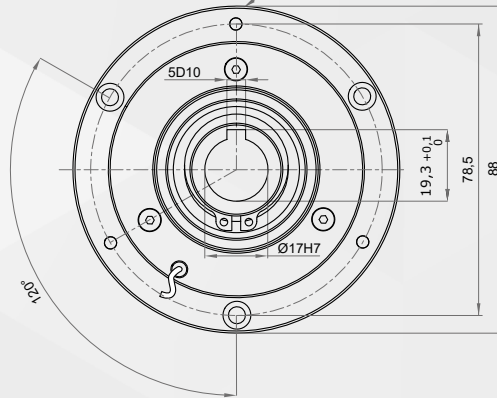

		<b>B.20</b>	<b>B.53</b>	<b>B.55</b>
Torque Nm	Coppia nominale Nm	2	5	5
Residual torque Nm	Coppia residua Nm	0,07	0,03	0,04
Max current A	Corrente massima A	1	1	1
Resistance at 20°C Ohm	Resistenza a 20°C Ohm	24	24	24
Voltage V (PWM)	Tensione V (PWM)	24	24	24
Power dissipation W	Potenza dissipabile W	24	70	75
Rpm min/max	Rpm min/max	40-2000	40-2000	40-2000
Weight kg	Peso kg	0,8	1,55	1,3



# B.121 SERIES

- Brake optional: radiator, fan 24V, 110V, 220V, clutch
- Optional del freno: radiatore, ventilatore 24V, 110V, 220V, frizione

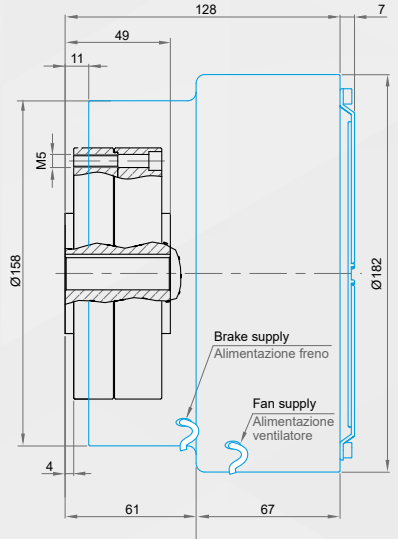
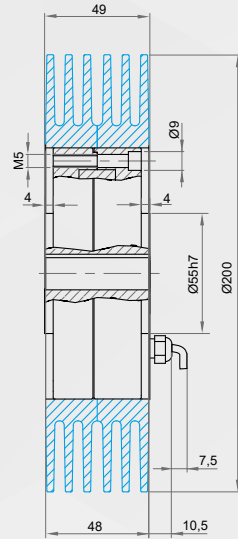
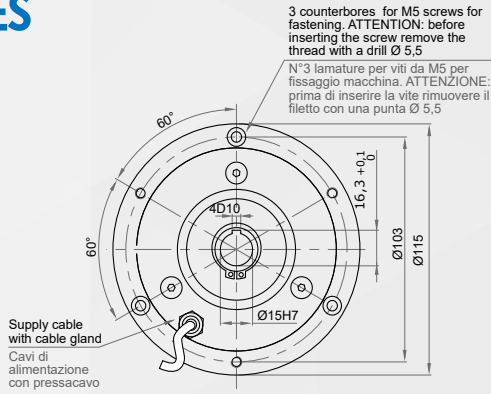

## B.121

Brake  
Freno

## B.121.R

Brake with radiator  
Freno con radiatore

## B.121.V

Brake with fan  
Freno con ventilatore

## C.121

Clutch  
Frizione

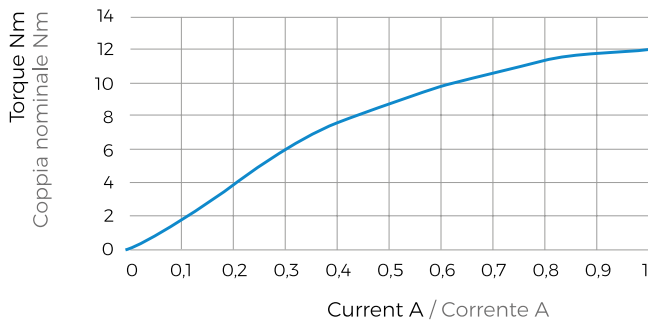
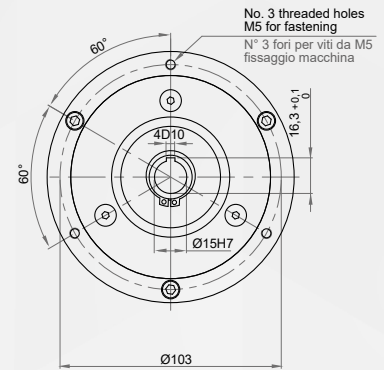
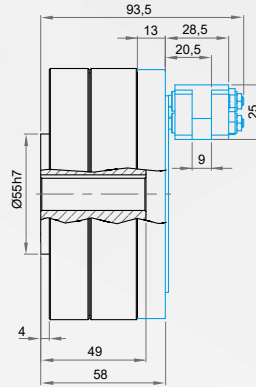
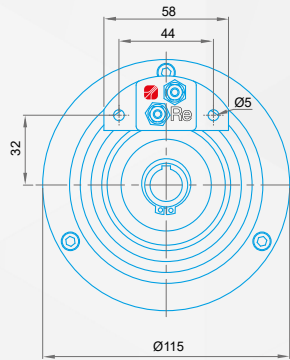

Torque	Coppia nominale	12 Nm
Residual torque	Coppia residua	0,06 Nm
Max current	Corrente massima	1 A
Resistance at 20°C	Resistenza a 20°C	24 Ohm
Voltage	Tensione	24 V (PWM)
<b>Power dissipation B.121</b>	<b>Potenza dissipabile B.121</b>	<b>80 W</b>
- with radiator B.121.R	- con radiatore B.121.R	160 W
- with fan B.121.V	- con ventilatore B.121.V	350 W
- C.121 at 500 rpm	- C.121 a 500 rpm	140 W
- C.121.R at 500 rpm	- C.121.R a 500 rpm	400 W
- C.121 at 1000 rpm	- C.121 a 1000 rpm	180 W
- C.121.R at 1000 rpm	- C.121.R a 1000 rpm	560 W
Rpm min-max	Rpm min-max	40-2000
Max working temperature	Max temp. esercizio	70°C
Weight B.121	Peso B.121	2,5 kg
Weight B.121.R	Peso B.121.R	4,5 kg
Weight B.121.V	Peso B.121.V	3,7 kg
Weight C.121	Peso C.121	3 kg
Weight C.121.R	Peso C.121.R	5 kg

For the special versions (low or high rpm, enhanced fan and mounting on vertical axis) please contact our technical dept.

Per le versioni speciali (applicazioni a basso o alto numero di giri, ventilazione potenziata e asse verticale di applicazione) contattate il nostro ufficio tecnico.



# B.351 SERIES

- Brake optional: radiator, fan 24V, 110V, 220V, clutch
- Optional del freno: radiatore, ventilatore 24V, 110V, 220V, frizione

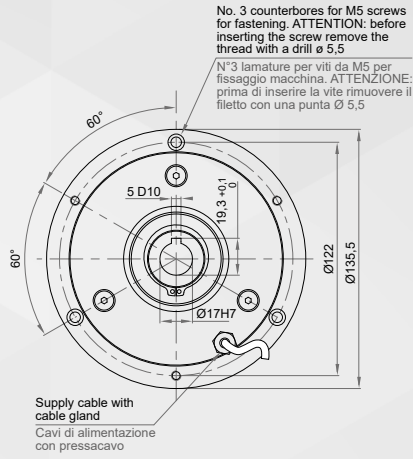

## B.351

Brake  
 Freno

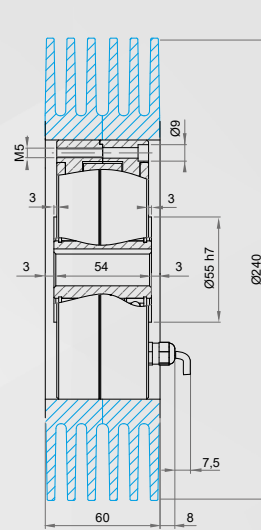

## B.351.R

Brake with radiator  
 Freno con radiatore

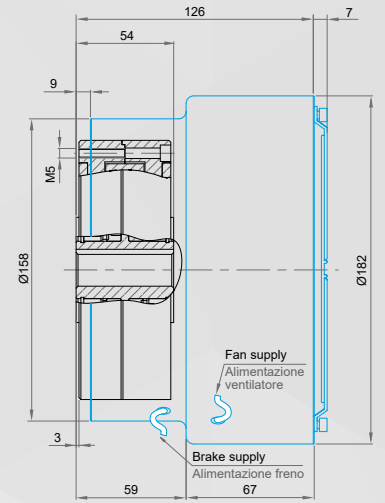

## B.351.V

Brake with fan  
 Freno con ventilatore

## C.351

Clutch  
 Frizione

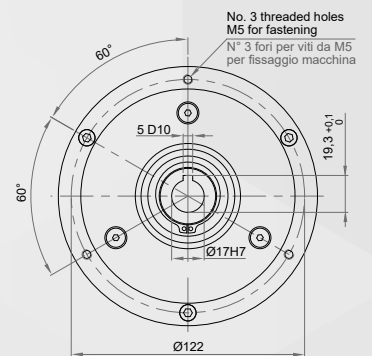
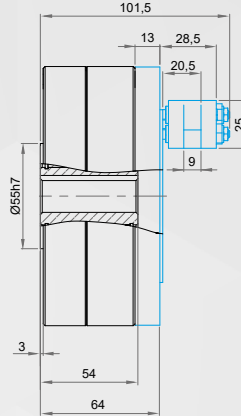
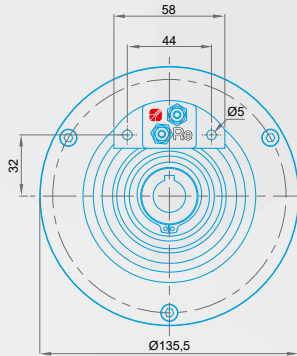

Torque	Coppia nominale	35 Nm
Residual torque	Coppia residua	0,2 Nm
Max current	Corrente massima	1 A
Resistance at 20°C	Resistenza a 20°C	24 Ohm
Voltage	Tensione	24 V (PWM)
<b>Power dissipation B.351</b>	<b>Potenza dissipabile B.351</b>	130 W
- with radiator B.351.R	- con radiatore B.351.R	230 W
- with fan B.351.V	- con ventilatore B.351.V	500 W
- C.351 at 500 rpm	- C.351 a 500 rpm	208 W
- C.351.R at 500 rpm	- C.351.R a 500 rpm	650 W
- C.351 at 1000 rpm	- C.351 a 1000 rpm	260 W
- C.351.R at 1000 rpm	- C.351.R a 1000 rpm	810 W
Rpm min-max	Rpm min-max	40-2000
Max working temperature	Max temp. esercizio	70°C
Weight B.351	Peso B.351	4 kg
Weight B.351.R	Peso B.351.R	7 kg
Weight B.351.V	Peso B.351.V	5,2 kg
Weight C.351	Peso C.351	4,6 kg
Weight C.351.R	Peso C.351.R	7,6 kg

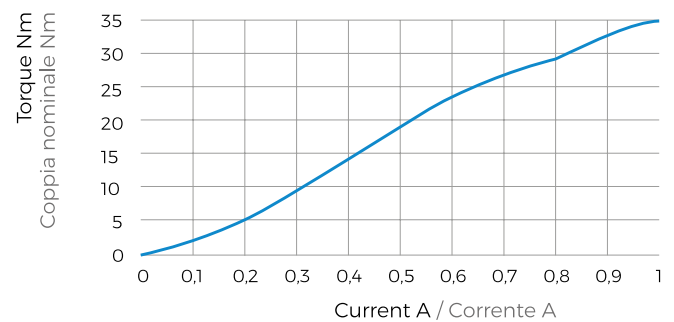

For the special versions (low or high rpm, enhanced fan and mounting on vertical axis) please contact our technical dept.

Per le versioni speciali (applicazioni a basso o alto numero di giri, ventilazione potenziata e asse verticale di applicazione) contattate il nostro ufficio tecnico.



# B.651 SERIES

- Brake optional: radiator, fan 24V, 110V, 220V, clutch
- Optional del freno: radiatore, ventilatore 24V, 110V, 220V, frizione

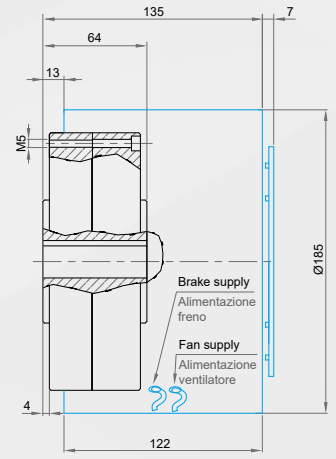
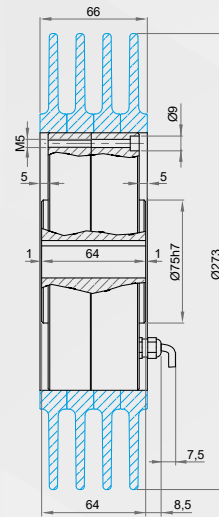
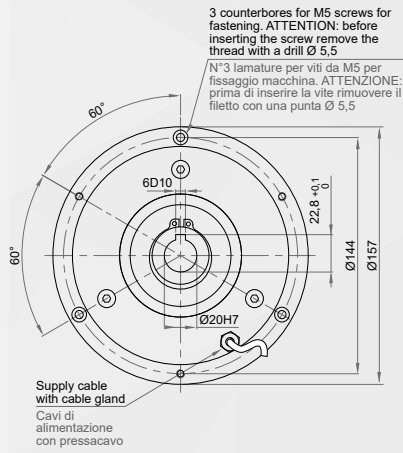

## B.651

Brake  
Freno

## B.651.R

Brake with radiator  
Freno con radiatore

## B.651.V

Brake with fan  
Freno con ventilatore

## C.651

Clutch  
Frizione

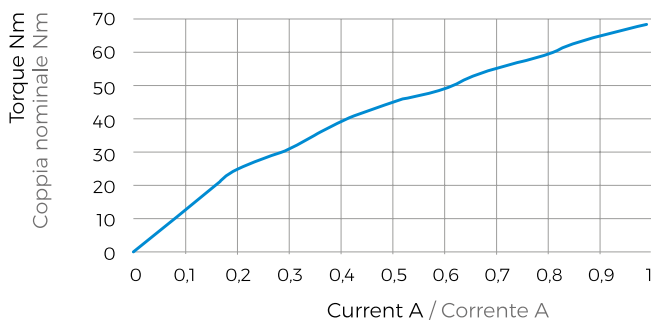
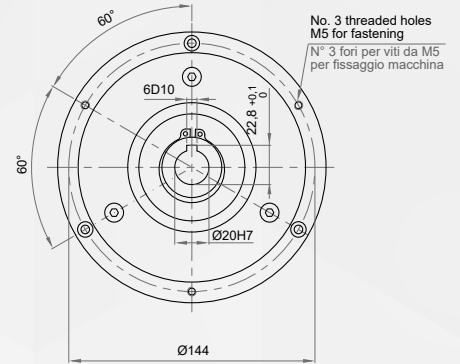
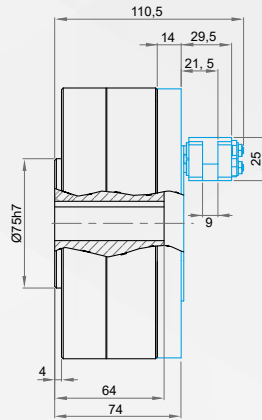
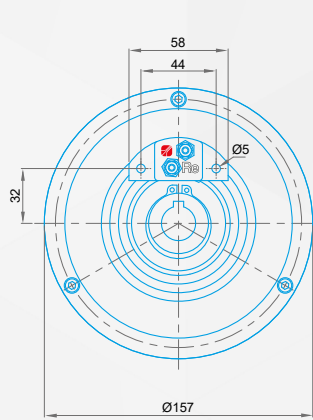

Torque	Coppia nominale	65 Nm
Residual torque	Coppia residua	0,4 Nm
Max current	Corrente massima	1 A
Resistance at 20°C	Resistenza a 20°C	24 Ohm
Voltage	Tensione	24 V (PWM)
<b>Power dissipation B.651</b>	<b>Potenza dissipabile B.651</b>	170 W
- with radiator B.651.R	- con radiatore B.651.R	400 W
- with fan B.651.V	- con ventilatore B.651.V	800 W
- C.651 at 500 rpm	- C.651 a 500 rpm	280 W
- C.651.R at 500 rpm	- C.651.R a 500 rpm	950 W
- C.651 at 1000 rpm	- C.651 a 1000 rpm	350 W
- C.651.R at 1000 rpm	- C.651.R a 1000 rpm	1200 W
Rpm min-max	Rpm min-max	40-2000
Max working temperature	Max temp. esercizio	70°C
Weight B.651	Peso B.651	6,5 kg
Weight B.651.R	Peso B.651.R	9 kg
Weight B.651.V	Peso B.651.V	8,8 kg
Weight C.651	Peso C.651	6,9 kg
Weight C.651.R	Peso C.651.R	9,4 kg

For the special versions (low or high rpm, enhanced fan and mounting on vertical axis) please contact our technical dpt.

Per le versioni speciali (applicazioni a basso o alto numero di giri, ventilazione potenziata e asse verticale di applicazione) contattate il nostro ufficio tecnico.



# B.1201 SERIES

- Brake optional: radiator, fan 24V, 110V, 220V, clutch
- Optional del freno: radiatore, ventilatore 24V, 110V, 220V, frizione

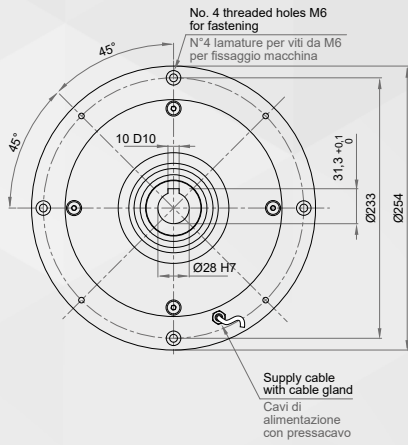

## B.1201

Brake  
Freno

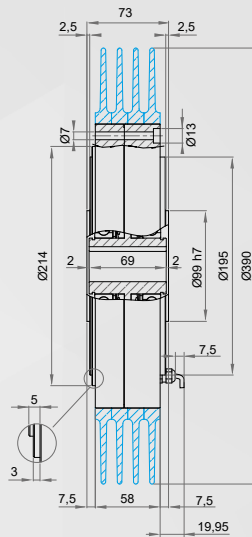

## B.1201.R

Brake with radiator  
Freno con radiatore

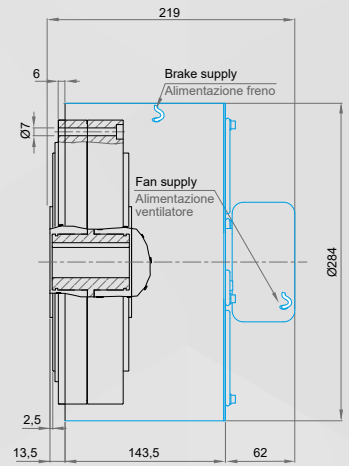

## B.1201.V

Brake with fan  
Freno con ventilatore

## C.1201

Clutch  
Frizione

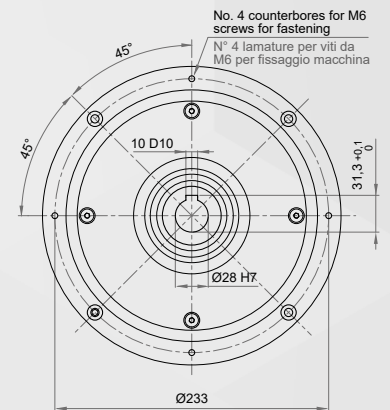
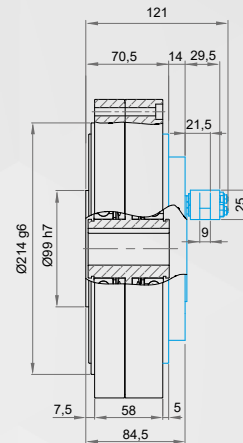
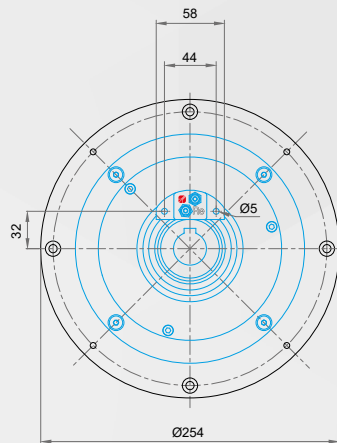

Torque	Coppia nominale	120 Nm
Residual torque	Coppia residua	0,5 Nm
Max current	Corrente massima	1 A
Resistance at 20°C	Resistenza a 20°C	24 Ohm
Voltage	Tensione	24 V (PWM)
<b>Power dissipation B.1201</b>	<b>Potenza dissipabile B.1201</b>	<b>330 W</b>
- with radiator B.1201.R	- con radiatore B.1201.R	650 W
- with fan B.1201.V	- con ventilatore B.1201.V	1500 W
- C.1201 at 500 rpm	- C.1201 a 500 rpm	650 W
- C.1201.R at 500 rpm	- C.1201.R a 500 rpm	1440 W
- C.1201 at 1000 rpm	- C.1201 a 1000 rpm	820 W
- C.1201.R at 1000 rpm	- C.1201.R a 1000 rpm	1800 W
Rpm min-max	Rpm min-max	40-2000
Max working temperature	Max temp. esercizio	70°C
Weight B.1201	Peso B.1201	16,5 kg
Weight B.1201.R	Peso B.1201.R	19 kg
Weight B.1201.V	Peso B.1201.V	19 kg
Weight C.1201	Peso C.1201	17 kg
Weight C.1201.R	Peso C.1201.R	19,5 kg

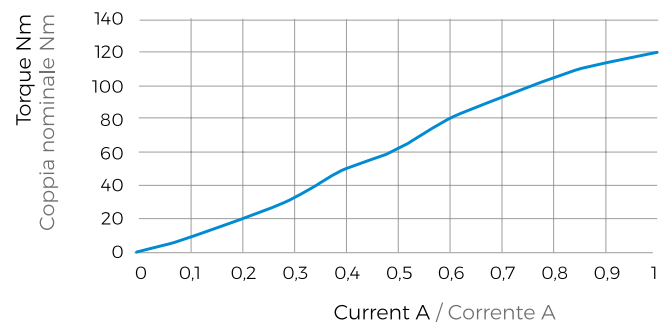

For the special versions (low or high rpm, enhanced fan and mounting on vertical axis) please contact our technical dept.

Per le versioni speciali (applicazioni a basso o alto numero di giri, ventilazione potenziata e asse verticale di applicazione) contattate il nostro ufficio tecnico.



# B.1701 SERIES

- Brake optional: radiator, fan 24V, 110V, 220V, clutch
- Optional del freno: radiatore, ventilatore 24V, 110V, 220V, frizione

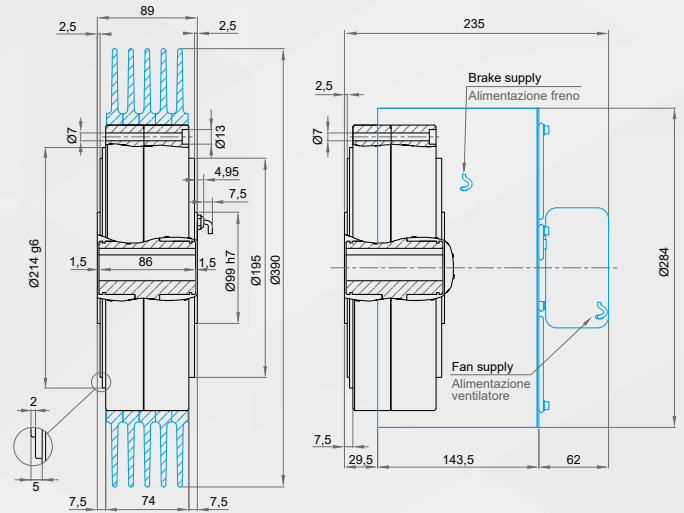
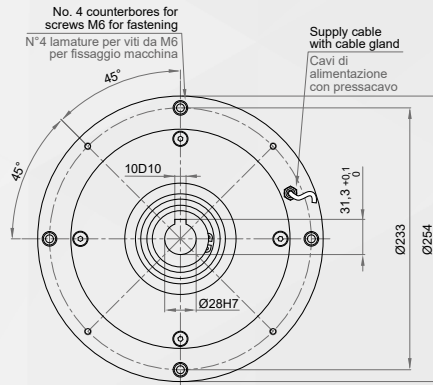

## B.1701

Brake  
Freno

## B.1701.R

Brake with radiator  
Freno con radiatore

## B.1701.V

Brake with fan  
Freno con ventilatore

## C.1701

Clutch  
Frizione

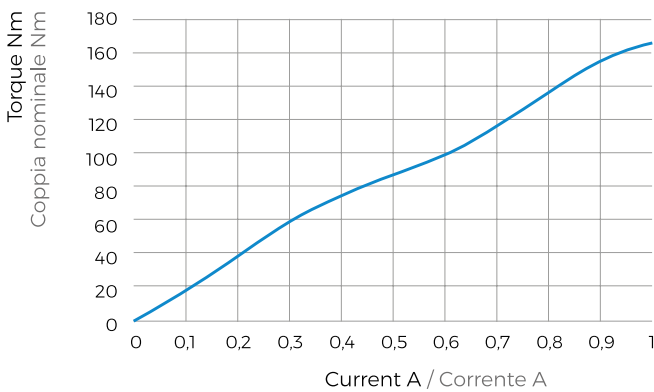
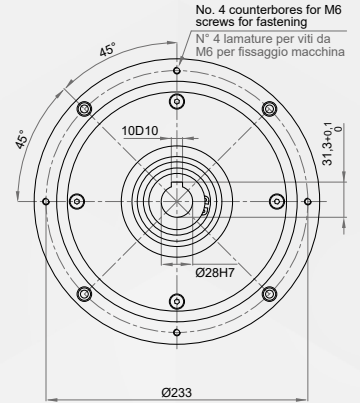
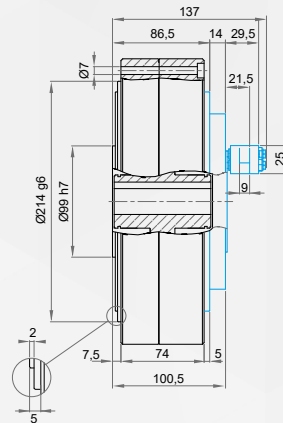
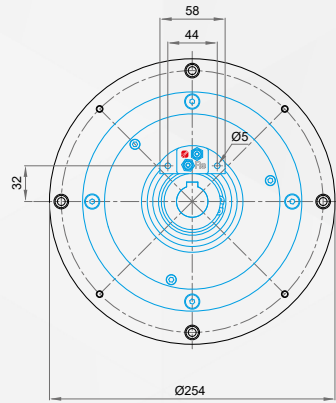

For the special versions (low or high rpm, enhanced fan and mounting on vertical axis) please contact our technical dept.

Per le versioni speciali (applicazioni a basso o alto numero di giri, ventilazione potenziata e asse verticale di applicazione) contattate il nostro ufficio tecnico.

Torque	Coppia nominale	170 Nm
Residual torque	Coppia residua	0,5 Nm
Max current	Corrente massima	1 A
Resistance at 20°C	Resistenza a 20°C	24 Ohm
Voltage	Tensione	24 V (PWM)
<b>Power dissipation B.1701</b>	<b>Potenza dissipabile B.1701</b>	<b>450 W</b>
- with radiator B.1701.R	- con radiatore B.1701.R	850 W
- with fan B.1701.V	- con ventilatore B.1701.V	1600 W
- C.1701 at 500 rpm	- C.1701 a 500 rpm	760 W
- C.1701.R at 500 rpm	- C.1701 1701.R a 500 rpm	1550 W
- C.1701 at 1000 rpm	- C.1701 a 1000 rpm	950 W
- C.1701.R at 1000 rpm	- C.1701.R a 1000 rpm	2250 W
Rpm min-max	Rpm min-max	40-2000
Max working temperature	Max temp. esercizio	70°C
Weight B.1701	Peso B.1701	22,5 kg
Weight B.1701.R	Peso B.1701.R	25,5 kg
Weight B.1701.V	Peso B.1701.V	25 kg
Weight C.1701	Peso C.1701	22,9 kg
Weight C.1701.R	Peso C.1701.R	26 kg



# B.2500 SERIES

- Brake optional: radiator, fan 24V, 110V, 220V, clutch
- Optional del freno: radiatore, ventilatore 24V, 110V, 220V, frizione

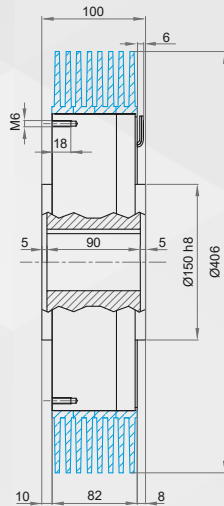

## B.2500.R

Brake with radiator  
Freno con radiatore

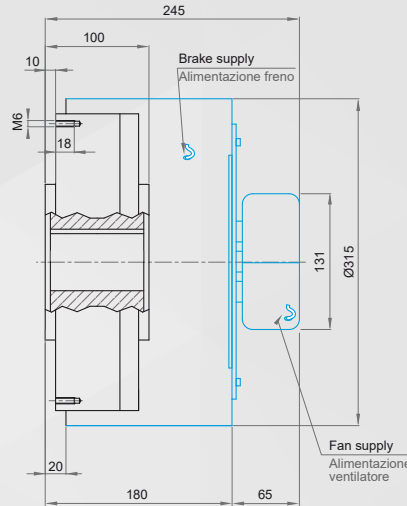

## B.2500.V

Brake with fan  
Freno con ventilatore

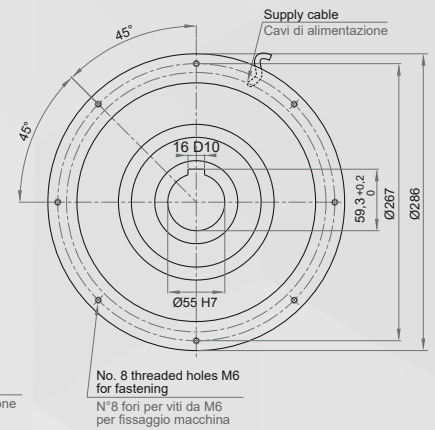

## B.2500

Brake  
Freno

## C.2500

Clutch  
Frizione

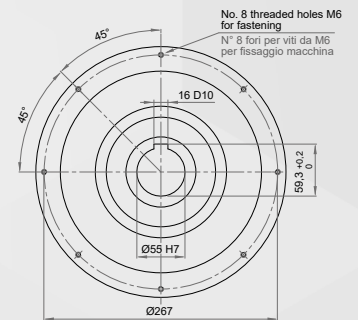
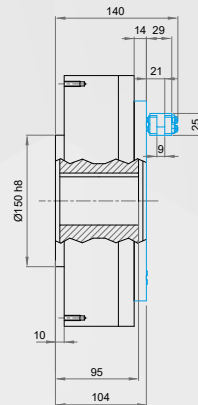
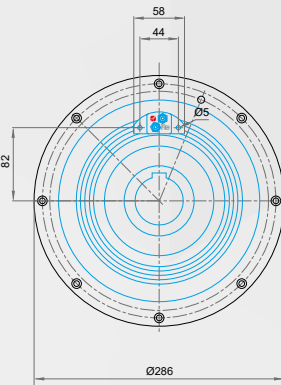

Torque	Coppia nominale	250 Nm
Residual torque	Coppia residua	3 Nm
Max current	Corrente massima	0,94 A
Resistance at 20°C	Resistenza a 20°C	25,5 hm
Voltage	Tensione	24 V (PWM)
<b>Power dissipation B.2500</b>	<b>Potenza dissipabile B.2500</b>	500 W
- with radiator B.2500.R	- con radiatore B.2500.R	900 W
- with fan B.2500.V	- con ventilatore B.2500.V	2000 W
- C.2500 at 500 rpm	- C.2500 a 500 rpm	1440 W
- C.2500.R at 500 rpm	- C.2500.R a 500 rpm	1650 W
- C.2500 at 1000 rpm	- C.2500 a 1000 rpm	1800 W
- C.2500.R at 1000 rpm	- C.2500.R a 1000 rpm	2400 W
Rpm min-max	Rpm min-max	40-1800
Max working temperature	Max temp. esercizio	70°C
Weight B.2500	Peso B.2500	32 kg
Weight B.2500.R	Peso B.2500.R	38 kg
Weight B.2500.V	Peso B.2500.V	38 kg
Weight C.2500	Peso C.2500	33 kg
Weight C.2500.R	Peso C.2500.R	40 kg

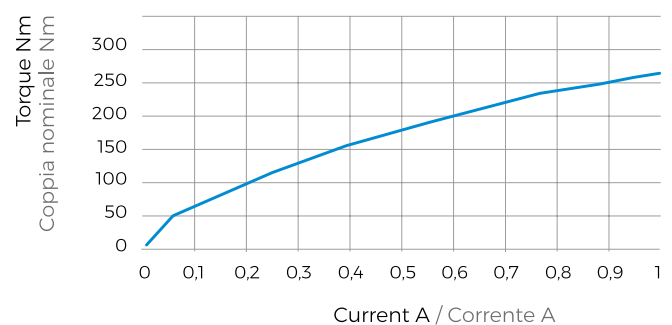

For the special versions (low or high rpm, enhanced fan and mounting on vertical axis) please contact our technical dept.

Per le versioni speciali (applicazioni a basso o alto numero di giri, ventilazione potenziata e asse verticale di applicazione) contattate il nostro ufficio tecnico.



# B.5000 SERIES

- Brake optional: radiator, fan 24V, 110V, 220V, clutch
- Optional del freno: radiatore, ventilatore 24V, 110V, 220V, frizione

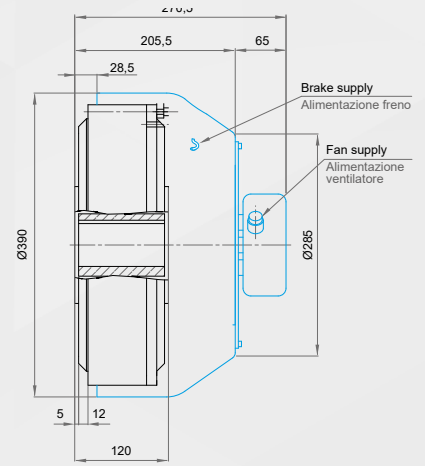
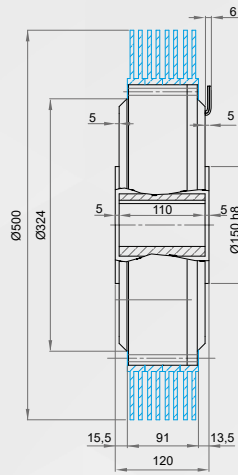
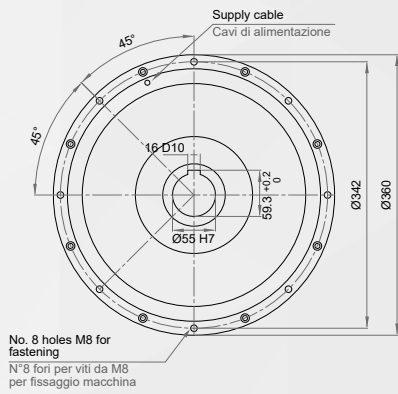

## B.5000

Brake  
Freno

## B.5000.R

Brake with radiator  
Freno con radiatore

## B.5000.V

Brake with fan  
Freno con ventilatore

## C.5000

Clutch  
Frizione

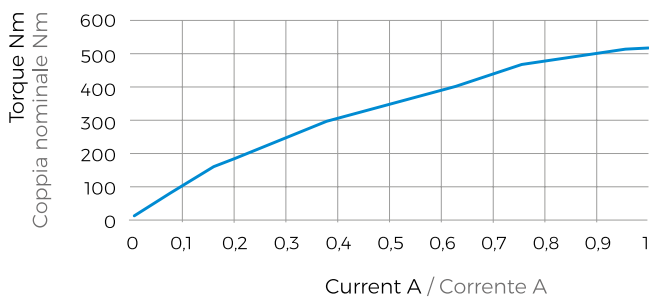
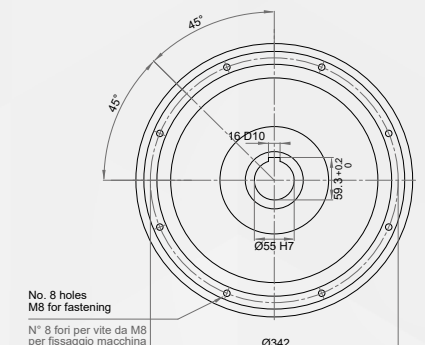
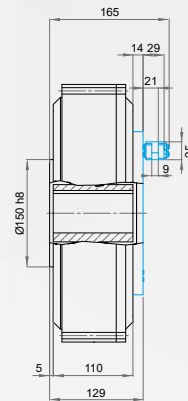
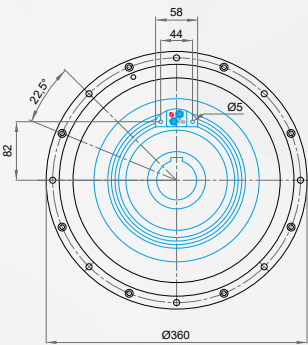

Torque	Coppia nominale	500 Nm
Residual torque	Coppia residua	6 Nm
Max current	Corrente massima	0,94 A
Resistance at 20°C	Resistenza a 20°C	25,5 Ohm
Voltage	Tensione	24 V (PWM)
<b>Power dissipation B.5000</b>	<b>Potenza dissipabile B.5000</b>	1300 W
- with radiator B.5000.R	- con radiatore B.5000.R	2500 W
- with fan B.5000.V	- con ventilatore B.5000.V	4000 W
- C.5000 at 500 rpm	- C.5000 a 500 rpm	2800 W
- C.5000.R at 500 rpm	- C.5000 1701.R a 500 rpm	4000 W
- C.5000 at 1000 rpm	- C.5000 a 1000 rpm	3500 W
- C.5000.R at 1000 rpm	- C.5000.R a 1000 rpm	5000 W
Rpm min-max	Rpm min-max	40-1500
Max working temperature	Max temp. esercizio	70°C
Weight B.5000	Peso B.5000	59 kg
Weight B.5000.R	Peso B.5000.R	62 kg
Weight B.5000.V	Peso B.5000.V	62 kg
Weight C.5000	Peso C.5000	62 kg
Weight C.5000.R	Peso C.5000.R	65 kg

For the special versions (low or high rpm, enhanced fan and mounting on vertical axis) please contact our technical dpt.

Per le versioni speciali (applicazioni a basso o alto numero di giri, ventilazione potenziata e asse verticale di applicazione) contattate il nostro ufficio tecnico.



# SPARE PARTS

## PARTI DI RICAMBIO

Watch the tutorial  
Guarda il tutorial

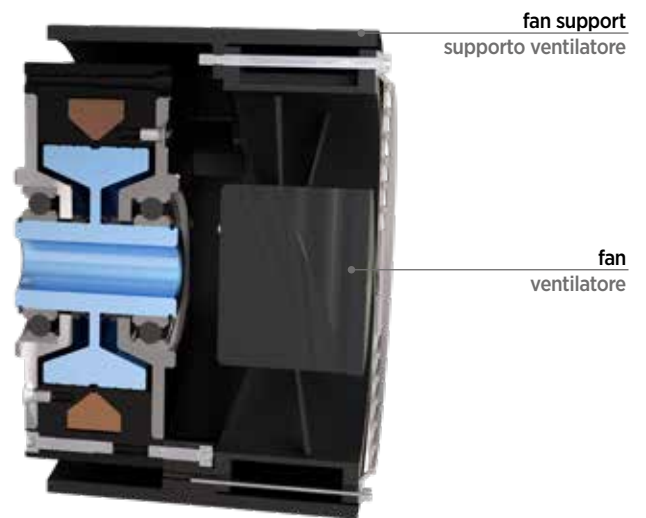
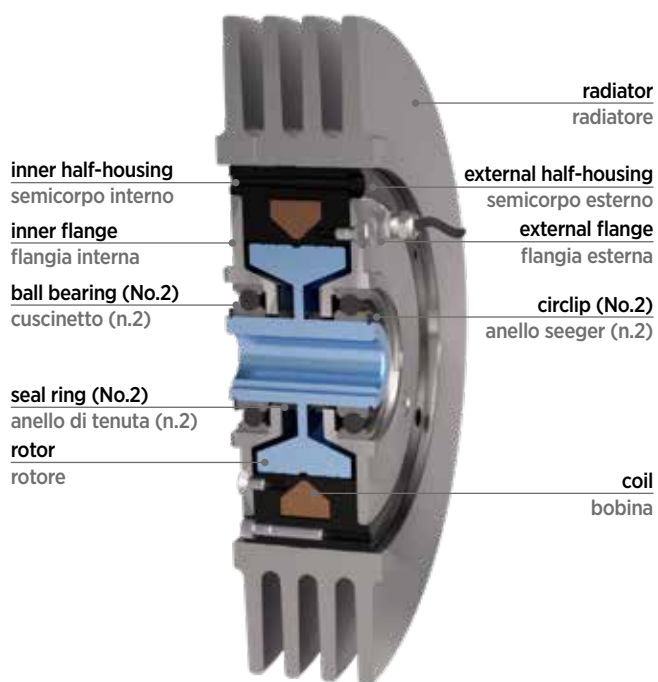

# LEO

## CURRENT REGULATOR FOR ELECTROMAGNETIC POWDER BRAKES

REGOLATORE DI CORRENTE PER FRENI ELETTROMAGNETICI A POLVERE

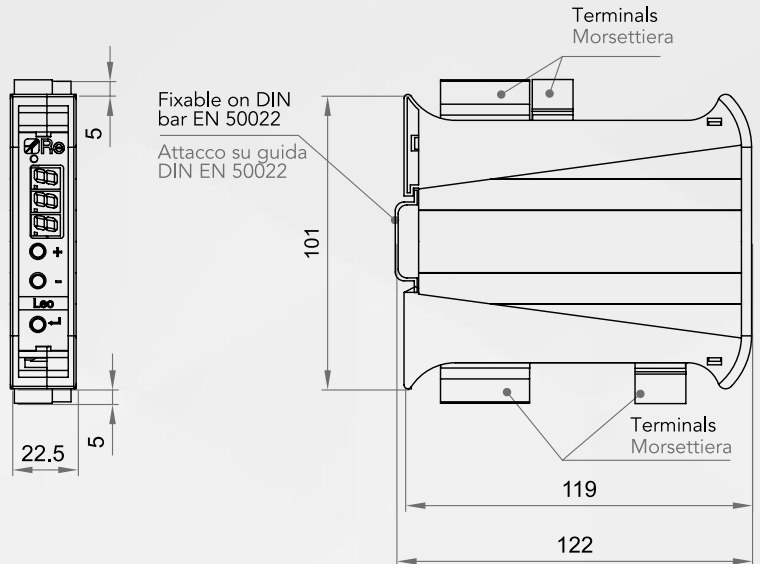

Leo is a microprocessor controlled digital current regulator that can be programmed by using the three buttons on the device panel. Leo's flexibility allows many different uses:

### Standard working method

in closed-loop as current regulator combined with a tension controller (t-one, T-two, PLC)

### Tension controller working method

- in open-loop systems as a tension controller combined with a sonar (servodiameter) or potentiometer;
- in closed-loop as a tension controller proportional-derivative, with dancer roller and potentiometer.

Leo guarantees brake/clutch torque stability irrespective of variations in the condition of the brake thanks to the current loop. The device can also cancel any residual magnetism (Antiresidual function) making it suitable for use in low torque applications without limitations. Small enough to be mounted on DIN guides Leo has been designed to take up the minimum amount of space while ensuring efficiency.

Leo è un regolatore di corrente digitale a microprocessore la cui programmazione è eseguibile tramite i tre tasti presenti sul pannello dello strumento. La sua versatilità permette diverse modalità di lavoro:

### Modalità standard

in sistemi a loop-chiuso come regolatore di corrente abbinato ad un regolatore di tiro (T-one, T-two, PLC)

### Modalità regolatore

- in sistemi a loop-aperto come controllo di tiro abbinato a sonar (servodiametro) o potenziometro;
- in sistemi a loop-chiuso come controllo di tiro di tipo proporzionale-derivativo, con ballerino e potenziometro.

La scheda Leo mantiene stabile la corrente applicata al freno/frizione indipendentemente dalle variazioni delle caratteristiche del freno grazie al loop di corrente. Lo strumento è inoltre in grado di annullare il magnetismo residuo (funzione Antiresidual) così da operare nel campo delle basse coppie. Applicabile su barra DIN Leo è stato studiato appositamente per occupare il minimo ingombro garantendo massima efficienza.



<b>Voltage supply</b> Alimentazione	<b>24 Vdc (± 10%)</b>
<b>Power</b> Potenza	<b>35 W max</b>
<b>Analog inputs</b> <b>0÷10 Vdc/4÷20 mA</b> Ingressi analogici 0÷10 Vdc/4÷20 mA	<b>1 brake control, or dancer roller or torque limit</b> <b>1 diameter</b> 1 comando freno o ballerino o limite di coppia 1 diametro
<b>Digital inputs 24 Vdc</b> Ingressi digitali 24 Vdc	<b>1 brake unlock (zero)</b> <b>1 priority stop</b> 1 sblocco freno (zero) 1 arresto prioritario
<b>Output 10 Vdc</b> Uscita 10 Vdc	<b>1 potentiometer supply</b> 1 alimentazione potenziometri
<b>PWM output -1÷1 A</b> Uscita PWM -1÷1 A	<b>1 electromagnetic brake</b> 1 freno elettromagnetico
<b>IP protection class</b> Grado di protezione IP	<b>IP20</b>
<b>Working temperature</b> Temperatura di lavoro	<b>0÷50° C</b>
<b>Weight</b> Peso	<b>150 g</b>
<b>Dimensions</b> Dimensioni	<b>22,5 x 101 x 119 mm</b>

#### Closed-loop current regulator Regolatore di corrente a loop-chiuso

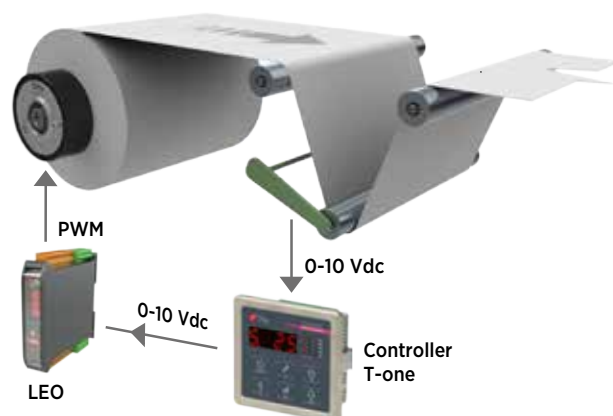

#### Open-loop tension regulator Regolatore di tensione a loop-aperto

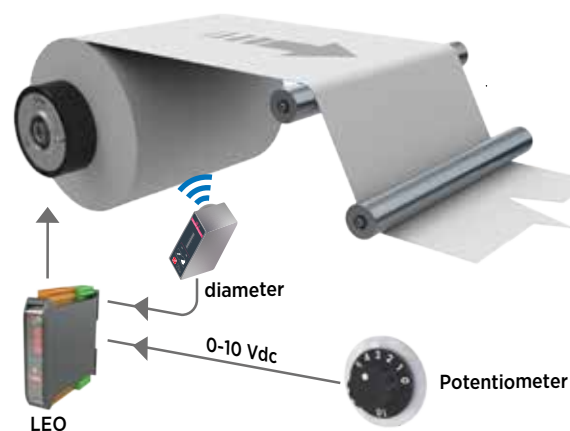

#### Closed-loop tension regulator Regolatore di tensione a loop-chiuso

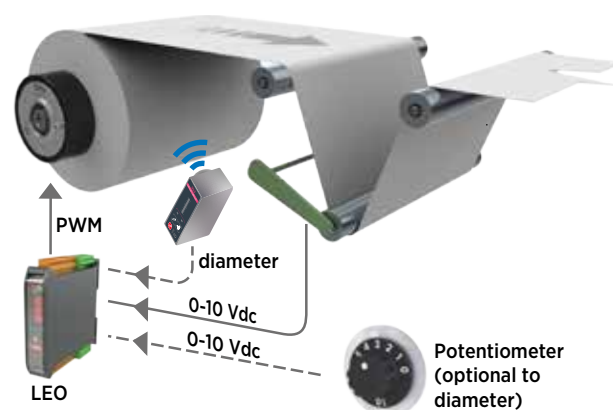



Company/Azienda	Contact/Contatto
City/Città	Country/Nazione
Tel	E-mail

Printing press-type/Tipo di macchina da stampa:

Type of web/Tipo di nastro	<input type="checkbox"/> Paper/Carta	<input type="checkbox"/> Cardboard/Cartone	<input type="checkbox"/> Film
	<input type="checkbox"/> Transparent film/Film trasparente	<input type="checkbox"/> Aluminium/Alluminio	<input type="checkbox"/> Other/Altro
Max ambient temperature/Max temperatura ambientale (°C)	<input type="checkbox"/> Explosion proof area/Zona antideflagrante		

**DATA REQUIRED/DATI RICHIESTI**

Max reel diameter/Diametro max bobina (Dmax): \_\_\_\_\_

Min reel diameter/Diametro min bobina (Dmin): \_\_\_\_\_

Max reel width/Larghezza max bobina (Lg max): \_\_\_\_\_

Min reel width/Larghezza min bobina (Lg min): \_\_\_\_\_

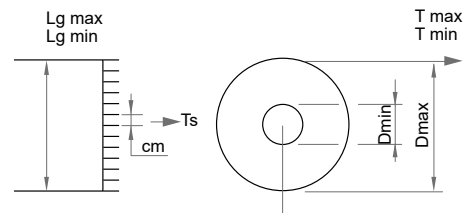

**TYPE OF MATERIAL/TIPO DI MATERIALE DA LAVORARE**

**APPLICAZIONE/APPLICATION**

Weight of the material/Peso del materiale:	<input type="checkbox"/> 1 brake for reel/1 freno per bobina
Thickness of the material/Spessore del materiale:	<input type="checkbox"/> 2 brakes for reel/2 freni per bobina
Nominal linear speed/Velocità lineare nominale (v):	<input type="checkbox"/> Clutch/Frizione
Fast stop time/Tempo di arresto rapido (t):	
Max reel weight/Peso massimo bobina:	

**DRIVE SHAFT DETAILS/DETTAGLI ALBERO:**

Shoulder/Spallamento (A): \_\_\_\_\_

Journal diameter/Diametro perno (B): \_\_\_\_\_

Distance end journal-key/Distanza fine perno-chiavetta (C): \_\_\_\_\_

Key lenght//Lunghezza chiavetta(D): \_\_\_\_\_

Key height/Altezza chiavetta (E): \_\_\_\_\_

Centering/Centraggio (F): \_\_\_\_\_

Center-center distance and holes No./Interasse e numero di fori (G): \_\_\_\_\_

Drive shaft lenght/Lunghezza perno (H): \_\_\_\_\_

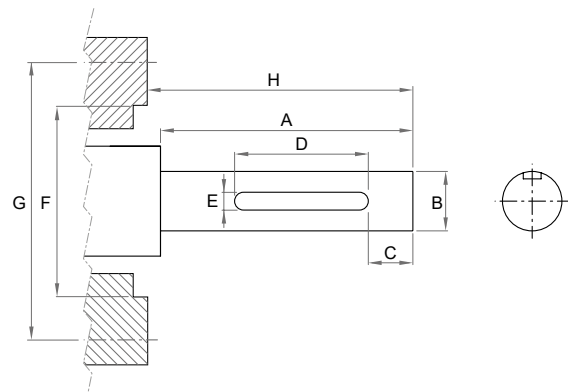

**Brake application**  
Applicazione freno

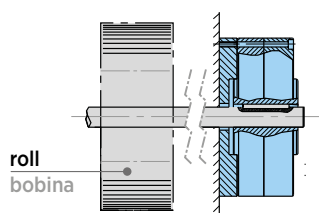

**Clutch application**  
Applicazione frizione

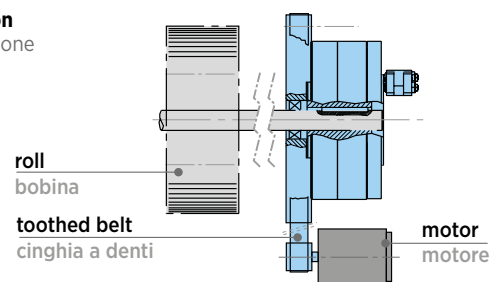

# APPLICATIONS

APPLICAZIONI

B.1201.V on slitter rewinder

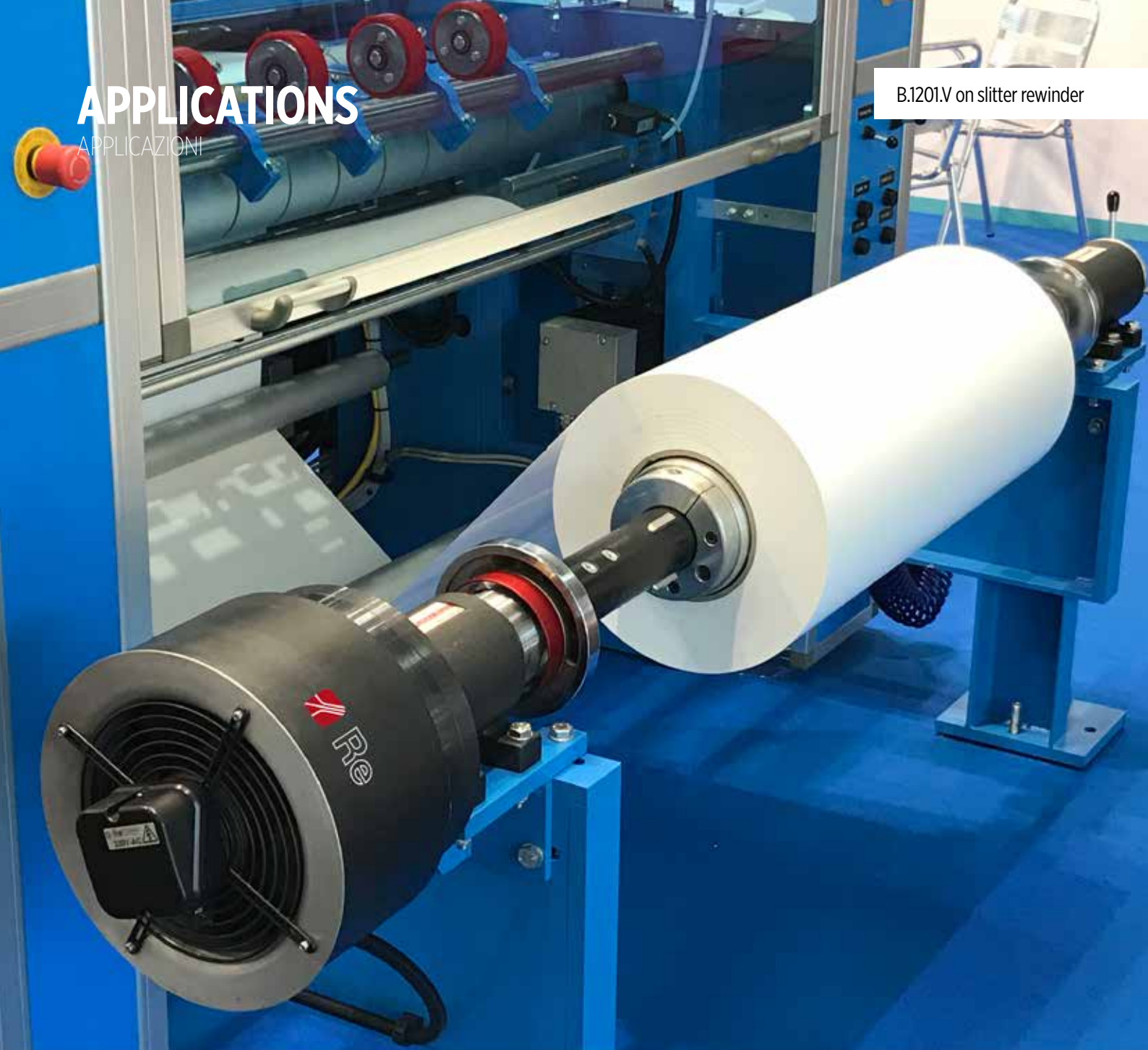

B.1701.V on double film unwinder



C.121.R on printing machine



B.121 on unwinder



[WWW.RE-SPA.COM](http://WWW.RE-SPA.COM)



**Registered office**  
Viale E. Caldara, 40  
20122 Milano Italy

**Headquarters**  
Via Firenze, 3  
20041 Bussero (MI) Italy

T +39 02 952430.200  
[info@re-spa.com](mailto:info@re-spa.com)